



# Air Brake Component Identification

Bendix Spicer Foundation Brake LLC  
A Bendix Commercial Vehicle Systems and Dana Corporation Joint Venture

1-800-AIR BRAKE  
(247-2725)

### 1 Dash Valves

MV-3™, PP-1™, TW-1™, PP-5™, PP-7™, PP-8™, TW-11™, PP-DC™

• MV-3™, PP-5™, PP-DC™ & TW-11™ available service new only.  
• PP-1™ and PP-7™ available in service and remanufactured exchange.

Valve Type	Catalog Page No.	Service Data Sheet
MV-3™	03-L-15	SD-03-3415
PP-1™	03-L-1	SD-03-3611
PP-5™	03-L-3B	SD-03-3611
PP-7™	03-L-4	SD-03-3617
PP-8™	03-L-4C	SD-03-3611
PP-DC™	03-L-17	SD-03-3619
TW-1™	03-L-8	SD-03-3602
TW-11™	Refer to Quick Reference	N/A

### 8 Brake Valves

E-6™, E-8™, E-10™, E-12™/E-15™, E-14™, E-15™

• Available in service new and remanufactured.  
• E-10™, E-12™, and E-15™ available in service new only.

Valve Type	Catalog Page No.	Service Data Sheet
E-6™	03-H-1	SD-03-817
E-7™	03-I-1	SD-03-819
E-8™	SD-03-830	SD-03-830
E-10™	SD-03-830	SD-03-830
E-12™	SD-03-826	SD-03-826
E-14™	SD-03-828	SD-03-828
E-15™	SD-03-826	SD-03-826

Refer to Quick Reference Catalog

### 11 Tractor Protection Valves

TP-3™, TP-4™, TP-5™, TP-3DC™

• Available in service and remanufactured exchange.

Valve Type	Catalog Page No.	Service Data Sheet
TP-3™	03-M-1	SD-03-3652
TP-3DC™	03-M-4	SD-03-3656
TP-4™	03-M-3	SD-03-3653
TP-5™	03-M-2	SD-03-3655

### 13 Spring Brake Valves

SR-1™, SR-7™, R-7™

• Available in service and remanufactured exchange.

Valve Type	Catalog Page No.	Service Data Sheet
SR-1™	03-A-5	SD-03-4608
SR-7™	03-A-6E	SD-03-9043
R-7™	03-A-9B	SD-03-4504

### 15 Relay Valves

R-12™, R-12™, R-14™, R-14™, R-12DC™, BP-R1™

• Available in service and remanufactured exchange.

Valve Type	Catalog Page No.	Service Data Sheet
R-12™	03-B-4C	SD-03-1064
R-14™	03-B-4E	SD-03-1064
R-12DC™	03-B-4L	SD-03-1068
BP-R1™	03-B-4H	SD-03-1067

### 2 Quick Release Valves

QR-1™, QR-1C™, QRN™, QRN-2™, QR-L™

• QRN™ and QRN-2™ available service new only.  
• Available in service and remanufactured exchange.

Valve Type	Catalog Page No.	Service Data Sheet
QR-1™	03-A-2	SD-03-901
QR-1C™	03-A-2B	SD-03-904
QRN™	03-A-2B	SD-03-905
QRN-2™	03-A-2C	SD-03-907
QR-L™	03-A-2D	SD-03-906

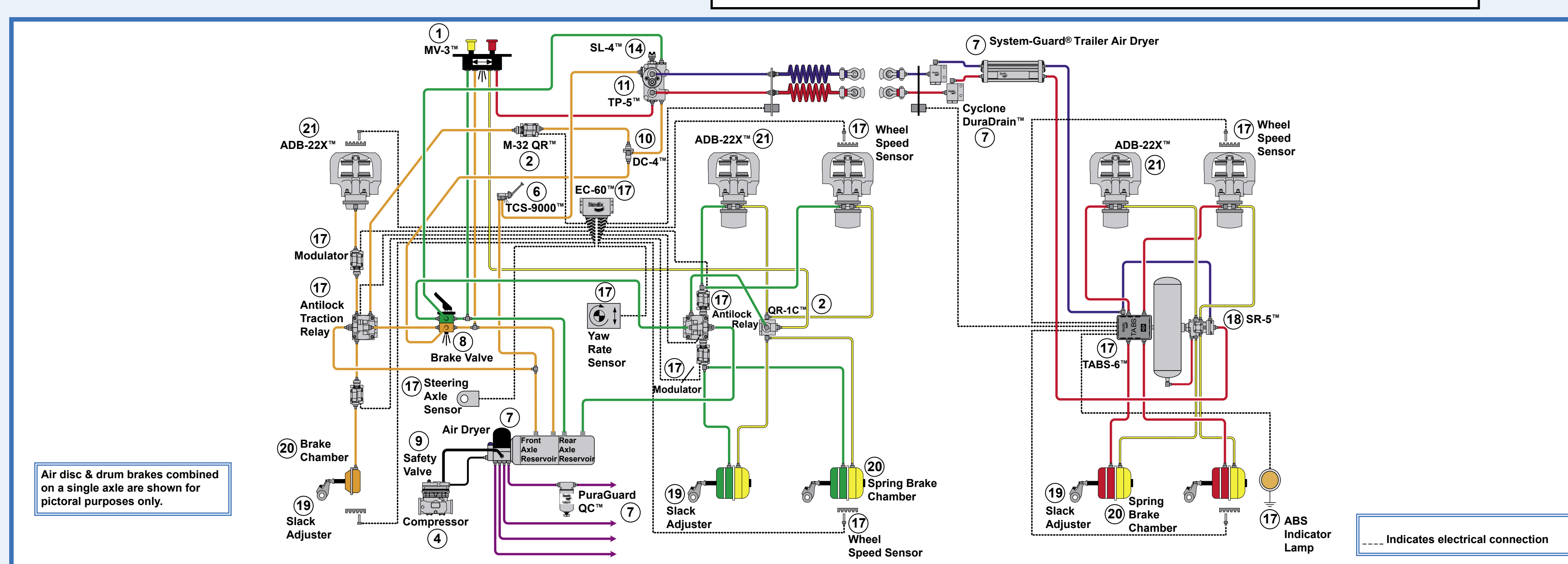

### 16 Trailer/Dolly Relay Valves

R-6™, RE-6™, R-12P™

• Available in service and remanufactured exchange.

Valve Type	Catalog Page No.	Service Data Sheet
R-6™	03-B-3	SD-03-1060
RE-6™/RE-6NC™	03-B-8	SD-03-1151
R-12P™	03-B-4J	SD-03-1063

### 3 Compressor Components

D-2™, D-2A™, IRV™, ICV™

• Available in service and remanufactured exchange.  
• IRV™ & ICV™ available in service only.

Component	Catalog Page No.	Service Data Sheet
D-2™ & D-2A™	01-A-1	SD-01-503
IRV™ Inlet Regulating Valve	01-A-2	SD-01-3408
ICV™ Inlet Check Valve	01-A-3	N/A

### 5 Limiting Quick Release Valves

LQ-2™, LQ-4™, LQ-5™

• Available in service and remanufactured exchange.

Valve Type	Catalog Page No.	Service Data Sheet
LQ-2™	03-A-04	SD-03-950
LQ-4™	03-A-04B	SD-03-951
LQ-5™	03-A-03C	SD-03-953

### 17 Antilock/Traction Stability Components

ATR-1™, ATR-2™, ATR-3™, EC-60™ Std. Frame Mount ECU, EC-60™ Std. Cab Mount ECU, EC-60™ Premium Frame Mount ECU, EC-60™ Adv. Cab Mount ECU, M-32QR™ Trailer ABS Modulators, M-32™ Modulators, TABS-6™ Trailer ABS, WS-24™ Wheel Speed Sensor, SAS-60™ Steering Angle Sensor, YAS-60™ Yaw Rate/Lateral Acceleration Sensor

Component	Catalog Page No.	Service Data Sheet
ATR-1™	SD-13-4811	SD-13-4811
ATR-2™	SD-13-4812	SD-13-4812
ATR-3™	SD-13-4815	SD-13-4815
EC-60™ Std. Frame Mount ECU	SD-13-4863	SD-13-4863
EC-60™ Std. Cab Mount ECU	SD-13-4863	SD-13-4863
EC-60™ Prem. Frame Mount ECU	SD-13-4863	SD-13-4863
EC-60™ Adv. Cab Mount ECU	SD-13-4869	SD-13-4869
M-32QR™ Trailer ABS Modulators	SD-13-4834	SD-13-4834
M-32™ Modulators	SD-13-4870	SD-13-4870
TABS-6™ Trailer ABS	SD-13-4767	SD-13-4767
WS-24™ Straight	SD-13-4860	SD-13-4860
WS-24™ 90°	SD-13-4860	SD-13-4860
SAS-60™ Steering Angle Sensor	SD-13-4869	SD-13-4869
YAS-60™ Yaw Rate/Lateral Acceleration Sensor	SD-13-4869	SD-13-4869

Refer to Catalog Section 13

### 4 Compressors

Tu-Flo® 400, Tu-Flo® 500, Tu-Flo® 700, BX-2150™, Tu-Flo® 550, DuraFlo™ 596, Tu-Flo® 501, Tu-Flo® 1400, Tu-Flo® 1000

• Available in service and remanufactured exchange.

Compressor Type	Catalog Page No.	Service Data Sheet
BX-2150™	01-L-1	SD-01-331
Tu-Flo® 400	01-C-1	SD-01-326
Tu-Flo® 500	01-D-1	SD-01-326
Tu-Flo® 501	01-E-1	SD-01-337
Tu-Flo® 550	01-O-1	SD-01-333
Tu-Flo® 700	01-K-1	SD-01-335
Tu-Flo® 750	01-N-1	SD-01-344
Tu-Flo® 1000	01-G-1	SD-01-326
Tu-Flo® 1400	01-M-1	N/A
DuraFlo™ 596	01-P-1	SD-01-670
BA-921®	N/A	N/A
BA-922®	N/A	SD-01-700

### 6 Hand Trailer Control Valves

TC-2™, TC-6™, TCS-9000™

• Available in service and remanufactured exchange.  
• TC-6™, TC-7™ and TCS-9000™ available service new only.

Valve Type	Catalog Page No.	Service Data Sheet
TC-2™	03-K-1	SD-03-813
TC-6™	03-K-5B	SD-03-821
TC-7™	03-K-6	SD-03-824
TCS-9000™	N/A	SD-03-3674

### 9 Safety Valves

ST-3™, ST-4™

• Valves available service new only.

Valve Type	Catalog Page No.	Service Data Sheet
ST-3™	03-A-1	SD-03-1901
ST-4™	Refer to Quick Reference	N/A

### 12 Single Check Valves

SC-1™ & SC-2™, SC-3™

• All SC-1™ and SC-2™ Check Valves are replaced with an SC-3™. Refer to catalog page for reference.  
• Valves available service new only.

Valve Type	Catalog Page No.	Service Data Sheet
SC-1™ & SC-2™	03-A-8	SD-03-2201
SC-3™	03-A-7	SD-03-2205

### 14 Miscellaneous Components

PR-2™, PR-4™, SL-4™, SL-5™, TR-2™, TR-3™, LP-2™, LP-3™, ET-2™, DV-2™, SV-1™, SS-1™

• Available in service new only.  
• DV-2™ available service and remanufactured exchange.

Component	Catalog Page No.	Service Data Sheet
PR-2™	03-A-11B	SD-03-2010
PR-4™	03-A-12	SD-03-2010
SL-4™	06-D-2	SD-06-1800
SL-5™	06-D-1	SD-06-1804
LP-2™	06-B-2	SD-06-1600
LP-3™	06-B-1	SD-06-1600
ET-2™	03-A-16	SD-03-4650
DV-2™	03-B-16B	SD-03-4650
SV-1™	03-A-14B	SD-03-4020
SS-1™	15-A-1	SD-15-4106
DV-2™	03-A-10	SD-03-2501
SS-1™	03-A-14	SD-03-4010

### 18 Trailer Spring Brake Valves

SR-2™, SR-4™, SR-5™

• Available in service and remanufactured exchange.

Valve Type	Catalog Page No.	Service Data Sheet
SR-2™	03-A-5B	SD-03-4510
SR-4™	03-A-5A	SD-03-4514
SR-4™ (new style)	03-A-5B	SD-03-4514
SR-5™	03-A-5C	SD-03-4516

### 7 Air Treatment

AD-2™, AD-4™, AD-9™, AD-SP™, AD-IP™, EverFlow™, System-Guard™, Cyclone DuraDrain™, PuraGuard QC™

• AD-2™ and AD-4™ available in remanufactured exchange only.  
• AD-9™, AD-IP™ and AD-IS™ available service new and remanufactured exchange.

Component	Catalog Page No.	Service Data Sheet
AD-2™	06-A-01	SD-08-2403
AD-4™	08-A-04	SD-08-2407
AD-9™	08-A-31	SD-08-2412
AD-IP™	08-A-24	SD-08-2418
AD-IP™	08-A-14	SD-08-2414
AD-SP™	08-A-9	SD-08-2415
EverFlow™	08-A-20	N/A
PuraGuard QC™	08-A-35	SD-08-1878
System-Guard™ Trailer Air Dryer	08-A-19	SD-08-2416
Dryer Reservoir Module	08-A-24	SD-98-9808
Cyclone DuraDrain™	08-A-37	SD-08-2402

### 10 Double Check Valves and Stop Light Switch

DC-4™, DS-1™, DS-2™

• Available in service and remanufactured exchange.  
• Double Check Valves and DS-2™ available new only.

Valve Type	Catalog Page No.	Service Data Sheet
DC-4™	03-A-6	SD-03-2202
DS-1™	06-C-1	SD-06-1804
DS-2™	06-C-2	N/A

### 19 Slack Adjusters

ASA-5™, Manual

• Available in service new only.

Slack Type	Catalog Page No.	Service Data Sheet
ASA-5™	05-A-22	SD-05-1269
Manual	05-A-1	SD-05-1200

### 20 Actuators

Brake Chamber, Spring Brake Chamber

• Available in service new only.

Type	Catalog Page No.	Service Data Sheet
Service Brake Chamber	Quick Reference	SD-02-1302
Spring Brake Chamber	Quick Reference	SD-02-4500

### 21 Air Disc Brake

ADB-22X™

• Available in OE only.

Type	Service Data Sheet
ADB-22X™	SD-23-7541

**TRUCKS AND TRUCK TRACTORS:**  
■ Charging ■ Primary ■ Secondary ■ Park (Supply) ■ Parking (Control)

**TRAILERS:**  
■ Trailer (Supply) ■ Trailer (Control) ■ Trailer (Park)

Reference Catalogs  
 BW1114 Quick Reference Catalog  
 BW5057 Air Brake Handbook  
 BW9100 Air Brake Service Parts Catalog  
 BW9600 Service Data Catalog  
 Web Site www.bendix.com